

Refrigerated Display Cases ODA for Promotions

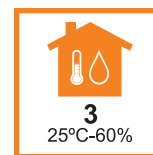

FEATURES:

Refrigerated display case ODA is a small mobile display case, perfect for impulse sales.



The showcase is easily adjustable in height and has a different angle tilt. In PF models, the shelf can be mounted on the required height depending on the laid out products. Good visibility inside the display case is achieved due to shockproof transparent sidewalls from PMMA and glasses located with front and back sides. Duct system allows evenly distribute cold throughout the interior volume. As an option, a wheel support is offered, protective shockproof bumper with extension system and price holders.

STANDARD COLOR OPTIONS:

gray&steel



SPECIFICATIONS:

Model	Length with sidewalls, mm → mm	Length without sidewalls, mm → mm	Horizontal exposure area, m ² 	Useful volume, m ³ 	Working temperature, °C 
PF07-12 VM 0,7-2	700	670	0,52	0,07	0...+4
PF07-12 VM 0,9-2	900	870	0,67	0,09	
PI07 VM 0,7-2	700	670	0,35	0,04	
PI07 VM 0,9-2	900	870	0,45	0,05	
PG07 VM 0,7-1	700	670	0,35	0,05	
PG07 VM 0,9-1	900	870	0,45	0,07	

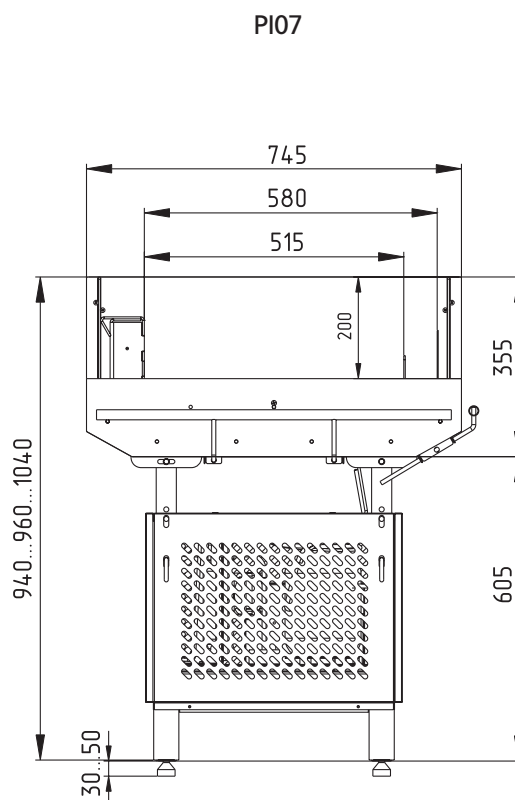
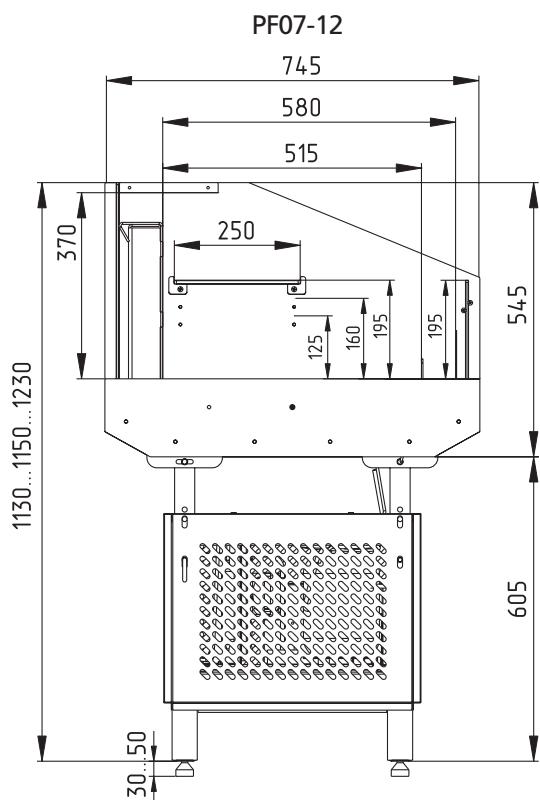

OPTIONS:

- protective bumper
- wheel support
- price holders
- branding



BRANDING

The manufacturer reserves the right to make changes to the design and equipment without prior notice.